



Telecom Performance 5x7mm TCXO / VCTCXO T / TV Series

CONNOR WINFIELD



2111 Comprehensive Drive

Aurora, Illinois 60505

Phone: 630-851-4722

Fax: 630-851-5040

www.conwin.com

Description:

Connor-Winfield's Txxx and TVxxx series are 5x7mm TCXO and VCTCXO products with exceptional frequency stability and low phase noise. Through the use of analog temperature compensation, these products are capable of holding Stratum 3 level temperature stabilities of ± 0.28 ppm over the commercial and industrial temperature ranges. Available in 4-pad or 10-pad surface mount footprints.

These products are designed for such applications as IEEE 1588 PTP and Synchronous Ethernet.

All models will meet ± 4.6 ppm accuracies for twenty years

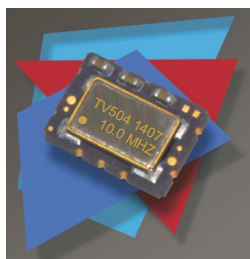

Features:

- Frequency Stabilities Available:
 - +/-0.28 ppm (6.4 to 50 MHz) ✓ STRATUM 3
 - +/-0.50 ppm (6.4 to 50 MHz)
 - +/-1.00 ppm or +/-2.00 ppm (6.4 to 54 MHz)
- Temperature Ranges Available:
 - 0 to 85°C, 0 to 70°C, -40 to 85°C or
 - 20 to 70°C Packages Available:
- T - Series: 5 x 7mm - 10 Pad
- TV - Series: 5 x 7mm - 4 Pad
- 3.3 Vdc Operation
- Output Logic: LVCMOS or Clipped Sinewave
- Fixed Frequency - TCXO
- Voltage Controlled - VCTCXO
- Low Jitter <0.50 ps RMS
- Low Phase Noise
- Tri-State Enable/Disable: (T Model Series Only)
- Tape and Reel Packaging
- RoHS Compliant / Lead Free ✓ RoHS

Applications:

- IEEE 1588 Applications
- Synchronous Ethernet slave clocks, ITU-T G.8262 EEC options 1 & 2
- Compliant to Stratum 3, GR-1244-CORE & GR-253-CORE
- Wireless Communications
- Small Cells
- Test and Measurement
- GPS

Standard Frequencies Available *

* 6.4, 9.72, 10, 10.24, 12.5, 12.8, 13.5, 19.2, 19.44, 20, 20.48, 25, 27, 38.88, 40 MHz

Available frequencies from the factory for small quantity orders or quick delivery.

Additional frequencies are available.

** Not all Models available at Digi-Key

Ordering Information

TV	5	0	4	- 010.0M
Type / Package TCXO / VCTCXO Series T = 5.0x7.0 mm 10 Pads TV = 5.0x7.0 mm 4 Pads	Temperature Range 3 = 0 to 85°C 5 = 0 to 70°C 6 = -40 to 85°C 7 = -20 to 70°C	Frequency Stability 0 = ± 0.28 ppm 1 = ± 0.50 ppm 2 = ± 1.00 ppm 3 = ± 2.00 ppm	Features 2 = TCXO, LVCMOS, 3.3 Vdc 3 = TCXO, Clipped Sinewave, 3.3 Vdc 4 = VCTCXO, LVCMOS, 3.3 Vdc 5 = VCTCXO, Clipped Sinewave, 3.3 Vdc	Output Frequency Frequency Format -xxx.xM Min -xxx.xxxxxM Max *Amount of numbers after the decimal point. M = MHz

Example Part Numbers

TV504-010.0M = 5x7mm 4 pad package, ± 0.28 ppm, 0 to 70°C, 3.3 Vdc, LVCMOS Output, VCTCXO
 T715-012.8M = 5x7mm 10 pad package, ± 0.50 ppm, -20 to 70°C, 3.3 Vdc, Clipped Sinewave Output, VCTCXO
 T522-050.0M = 5x7mm 10 pad package, ± 1.0 ppm, 0 to 70°C, 3.3 Vdc, LVCMOS Output, TCXO
 TV602-010.0M = 5x7mm 4 pad package, ± 0.28 ppm, -40 to 85°C, 3.3 Vdc, LVCMOS Output, TCXO

Note: Models T622 and TV622 have recommended replacement parts TJ6F and TVJ6F for the following frequencies 10, 12.8, 18.432, 20, 25, 25.6, 27, 38.88, 49.152, and 50 MHz. Please refer to the product data sheet TX452 for more information on these models.





Absolute Maximum Ratings

Parameter	Minimum	Nominal	Maximum	Units	Notes
Storage Temperature	-55	-	95	°C	
Supply Voltage (Vcc)	-0.5	-	6.0	Vdc	
Input Voltage	-0.5	-	Vcc + 0.5	Vdc	

Operating Specifications

Parameter	Minimum	Nominal	Maximum	Units	Notes
Output Frequency (Fo)					
Models Tx0x, TVx0x	6.4	-	50	MHz	
Models Tx1x, TVx1x	6.4	-	50	MHz	
Models Tx2x, TVx2x	6.4	-	54	MHz	
Models Tx3x, TVx3x	6.4	-	54	MHz	
Operating Temperature Range	(See Ordering Information for full part number)				
Models T3xx, TV3xx	0	-	85	°C	
Models T5xx, TV5xx	0	-	70	°C	
Models T6xx, TV6xx	-40	-	85	°C	
Models T7xx, TV7xx	-20	-	70	°C	
Frequency Calibration @ 25 °C	-1.0	-	1.0	ppm	1
Frequency Stability (See Ordering Information for full part number) Per STRATUM 3 GR-1244-CORE					
Frequency Stability ±0.28 ppm is only available in the frequency range of 6.4 to 50 MHz.					
Models Tx0x, TVx0x	-0.28	-	0.28	ppm	2
Holdover Stability	-0.32	-	0.32	ppm	3
Constant Temperature Stability	-40	-	40	ppb	Over 24 Hrs.
Frequency Stability (See Ordering Information for full part number)					
Models Tx1x, TVx1x	-0.50	-	0.50	ppm	2
Models Tx2x, TVx2x	-1.00	-	1.00	ppm	2
Models Tx3x, TVx3x	-2.00	-	2.00	ppm	2
Frequency vs. Load Stability	-0.05	-	0.05	ppm	±5%
Frequency vs. Voltage Stability	-0.05	-	0.05	ppm	±5%
Static Temperature Hysteresis	-	-	0.40	ppm	4
Freq. shift after reflow soldering	-1.0	-	1.0	ppm	5
Long Term Stability	-1.0	-	1.0	ppm	6
Aging					
per Life (20 Years)	-3.0	-	3.0	ppm	
per Day	-40	-	40	ppb	
Total Frequency Tolerance	-4.6	-	4.6	ppm	7
Supply Voltage (Vcc)	3.135	3.30	3.465	Vdc	
Supply Current (Icc) LVCMOS	-	2.1	6.0	mA	
Clipped Sinewave	-	1.3	2.9	mA	
Jitter:					
Period Jitter	-	3.0	5.0	ps RMS	
Integrated Phase Jitter (12K to Fo/2)	-	0.3	1.0	ps RMS	8
Allan Deviation (1s)	-	1.0E-10	-		
G-sensitivity	-	-	2.0	ppb/g	
Typical SSB Phase Noise					
For Fo	10.0 MHz	25.0 MHz	50.0 MHz		
@ 10 Hz offset	-98	-90	-73	dBc/Hz	
@ 100 Hz offset	-125	-120	-103	dBc/Hz	
@ 1 KHz offset	-143	-140	-134	dBc/Hz	
@ 10 KHz offset	-151	-151	-151	dBc/Hz	
@ 100 KHz offset	-152	-152	-152	dBc/Hz	
@ 1 MHz offset	-155	-154	-154	dBc/Hz	
Start-Up Time	-	-	10	ms	



Control Voltage Input Characteristics

Parameter	Minimum	Nominal	Maximum	Units	Notes
Control Voltage	0.3	1.65	3.0	V	
Frequency Pullability	±10	±12	-	ppm	
Pull Slope (Vc=1.65V)	-	8.00	-	ppm/V	
Control Voltage Slope	Positive Slope				
Monotonic Linearity	-	-	5	%	
Input Impedance	100K	-	-	Ohm	
Modulation Bandwidth (3dB)	10	-	-		KHz

OE Enable /Disable Input Characteristics (Pad 8) T Series only

Parameter	Minimum	Nominal	Maximum	Units	Notes
Enable Input Voltage -(Vih)	70%Vcc	-	-	Vdc	9
Disable Input Voltage - (Vil)	-	-	30%Vcc	Vdc	9

Function	Output
Low:	Disabled (High Impedance)
High or Open:	Enabled

LVC MOS Output Characteristics

Parameter	Minimum	Nominal	Maximum	Units	Notes
Load (CL)	-	15	-	pF	10
Voltage (High) (Voh)	90%Vcc	-	-	Vdc	
(Low) (Vol)	-	-	10%Vcc	Vdc	
Current (High) (Ioh)	-4	-	-	mA	
(Low) (Iol)	-	-	4	mA	
Duty Cycle at 50% of Vcc	45	50	55	%	
Rise / Fall Time 10% to 90%	-	4	8	ns	

Clipped Sinewave Output Characteristics

Parameter	Minimum	Nominal	Maximum	Units	Notes
Load (RC)					11
Output Load Resistance	-	10K	-	Ohm	12
Output Load Capacitance	-	10	-	pF	
Output Voltage (< 40 MHz)	1.0	1.2	-	V	pk-pk
Output Voltage (=>40 MHz)	0.8	1.0	-	V	pk-pk
Output Impedance	-	200	-	Ohms	

Package Characteristics

Package	Hermetically sealed ceramic package with grounded metal cover
---------	---

Environmental Characteristics

Vibration:	Vibration per Mil Std 883E Method 2007.3 Test Condition A.
Shock:	Mechanical Shock per Mil Std 883E Method 2002.4 Test Condition B.
Soldering Process:	RoHS compliant lead free. See soldering profile on page 4.

Notes:

- Initial calibration @ 25°C. ±2°C, for VCTCXO's Vc = 1.65V. Specifications at time of shipment
- Frequency stability vs. change in temperature. $[\pm(F_{max}-F_{min})/(2 \cdot F_0)]$. For VCTCXO's - Vc = 1.65V
- Inclusive of frequency stability, supply voltage change (±1%), aging, for 24 hours. Per STRATUM 3 GR-1244-CORE.
- Frequency change after reciprocal temperature ramped over the operating range. Frequency measured before and after at 25°C
- Two consecutive solder reflows after 1 hour recovery @ 25°C.
- Frequency drift over 1 year @ 25°C.
- Inclusive of calibration @ 25°C, frequency vs. change in temperature, change in supply voltage (±5%), load change (±5%), reflow soldering process and 20 years aging.
- BW = 12 KHz to 20 MHz
- Leave Pad 8 on the T Series unconnected if enable / disable function is not required. When tri-stated, the output stage is disabled but the oscillator and compensation circuit are still active (current consumption < 1 mA).
- Attention: To achieve optimal frequency stability, and in some cases to meet the specification stated on this data sheet, it is required that the circuit connected to this TCXO output must have the equivalent input capacitance that is specified by the nominal load capacitance. Deviations from the nominal load capacitance will have a graduated effect on the stability of approximately 20 ppb per pF load difference.
- Load components are required for proper operation of the device.
- Output is AC coupled.

Bulletin	Tx176
Page	3 of 6
Revision	24
Date	17 Nov 2022



T Series Package Outline

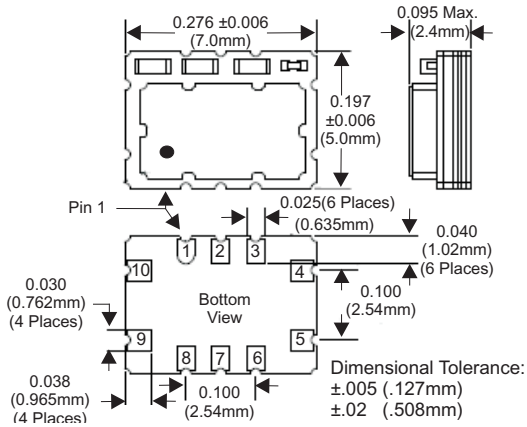

T Series Suggested Pad Layout

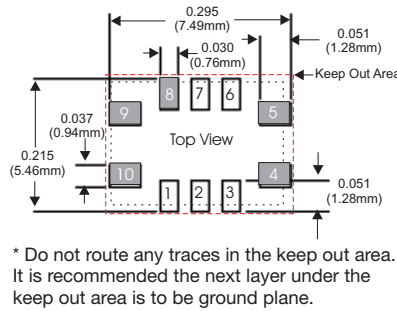

T Series Pad Connections

- 1: Do Not Connect
- 2: Do Not Connect
- 3: Do Not Connect
- 4: Ground
- 5: Output
- 6: Do Not Connect
- 7: Do Not Connect
- 8: Enable / Disable (OE)
- 9: Supply Voltage (Vcc)
- 10: VCTCXO: Control Voltage (Vc)
TCXO: N/C

TV Series Package Outline

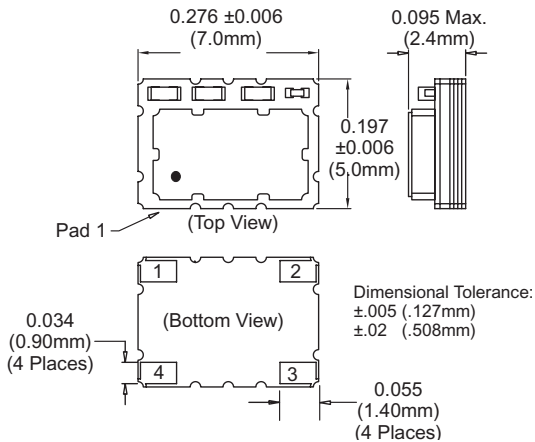

TV Series Suggested Pad Layout

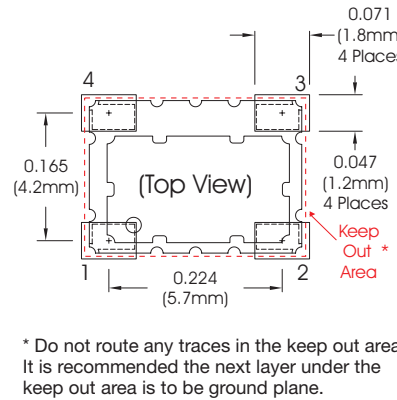

TV Series Pad Connections

- 1: VCTCXO: Voltage Control (Vc)
TCXO: N/C
- 2: Ground
- 3: Output
- 4: Supply (Vcc)

Solder Profile

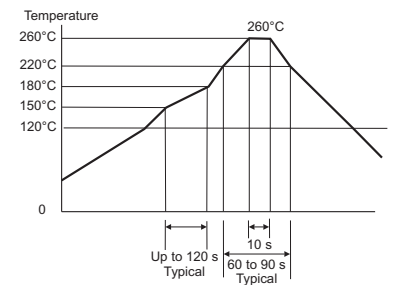

Meets IPC/JEDEC J-STD-020C

Marking Information

The following are examples of possible marking configurations

The marking varies with design configuration. All marking configurations below are valid.

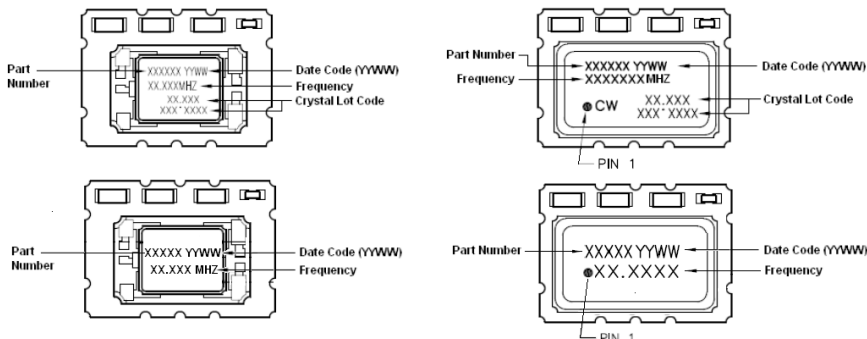

2 CHARACTER DATE CODE

Y = Year	M = Month
8 = 2018	A = January
9 = 2019	B = February
0 = 2020	C = March
1 = 2021	D = April
	E = May
	F = June
	G = July
	H = August
	J = September
	K = October
	M = November
	N = December

T Series Design Recommendations

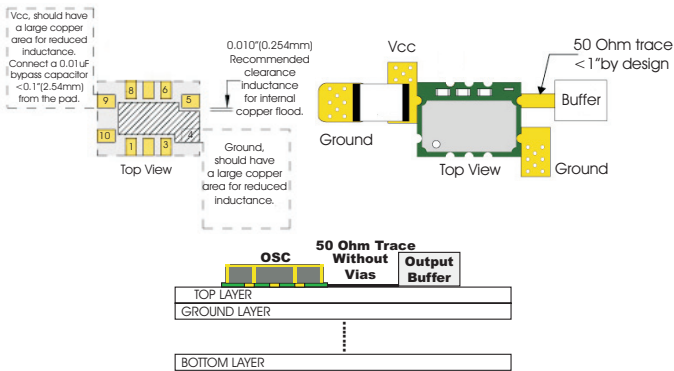

TV Series Design Recommendations

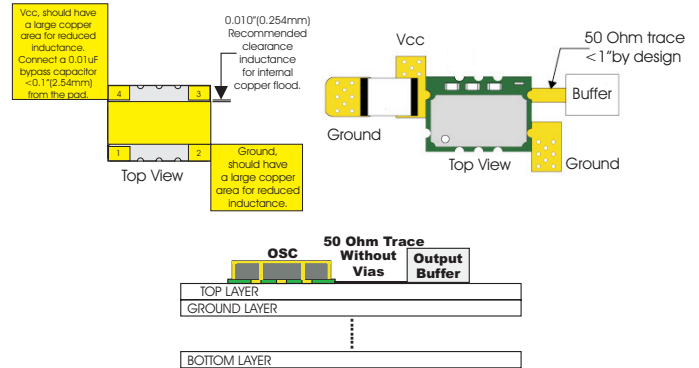

T Series LVC MOS Test Circuit

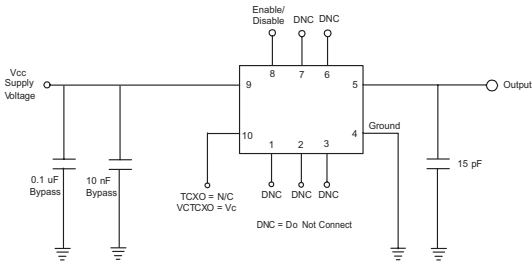

TV Series LVC MOS Test Circuit

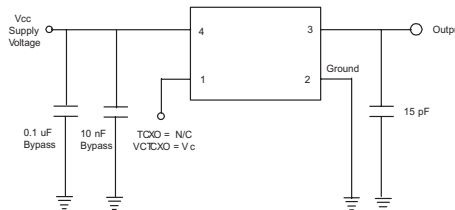

LVC MOS Output Waveform

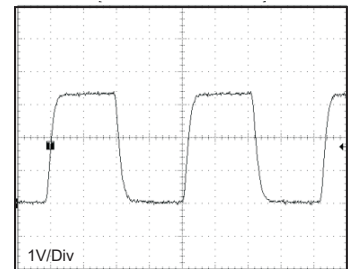

T Series Clipped Sinewave Test Circuit

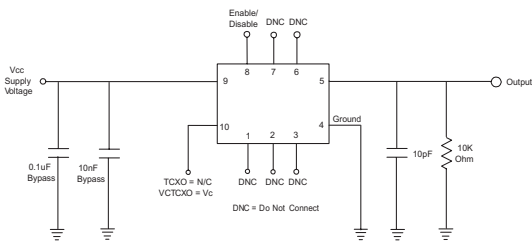

TV Series Clipped Sinewave Test Circuit

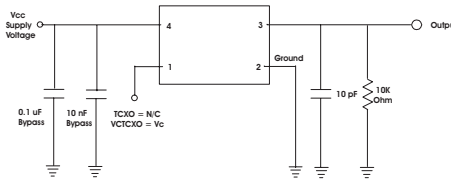

Clipped Sinewave Output Waveform

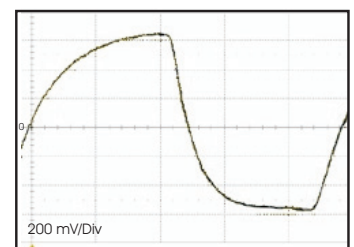

Note: The clipped sinewave output is AC coupled

Phase Noise Information

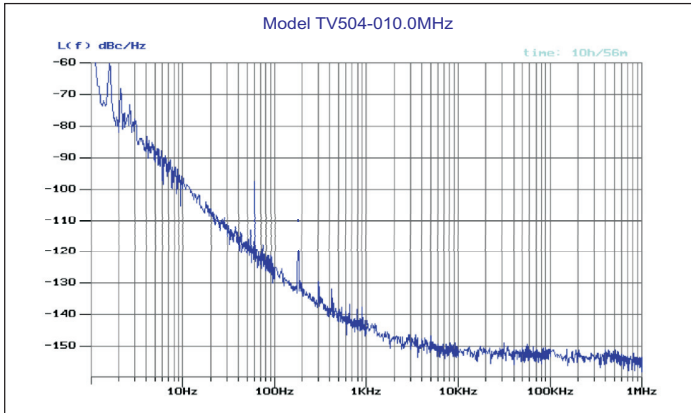

TIE

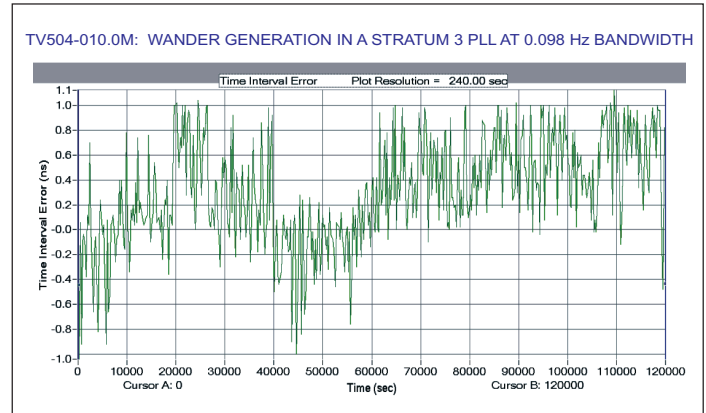

MTIE

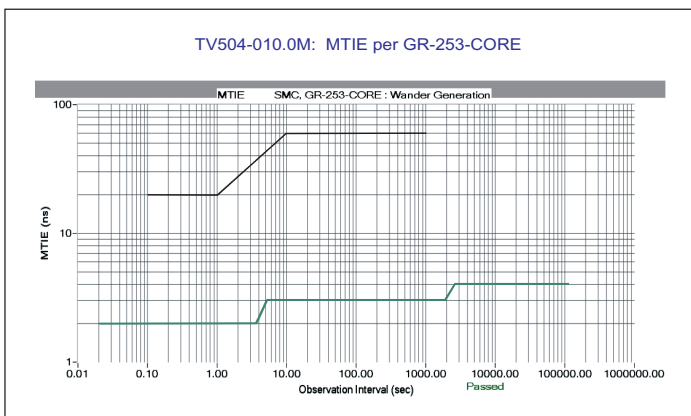

TDEV

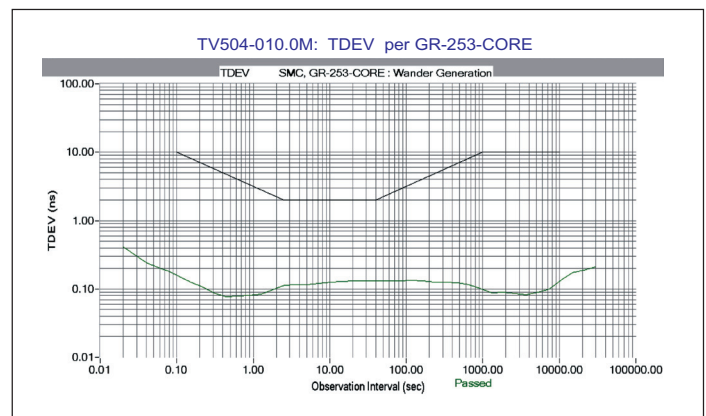

5x7mm Tape and Reel Information

MEETS EIA-481A AND EIAJ-1009B
700 PCS/REEL MAXIMUM.

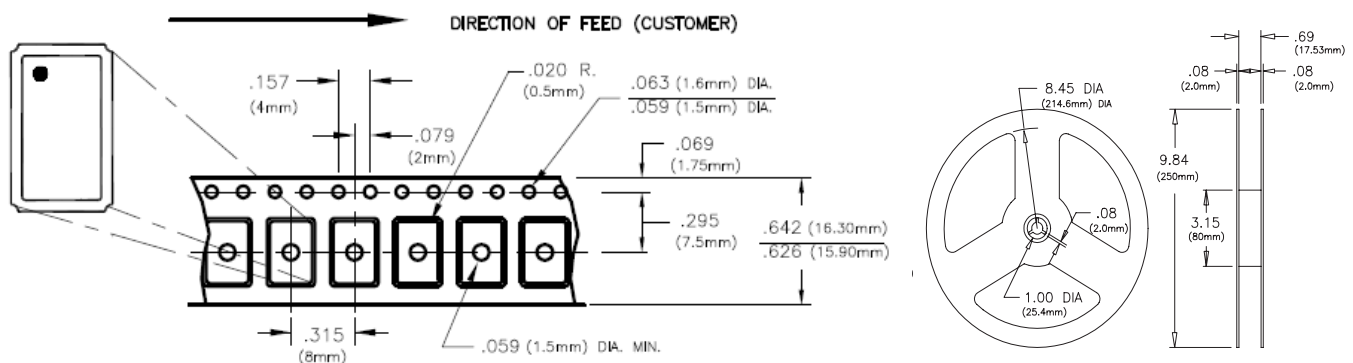

Revision History

Revision	Date	Action
19	04/01/15	Updated Frequency Stabilities
20	07/27/16	Extended operating frequency range, and updated standard frequency list
21	05/10/17	Added marking variations
22	08/02/18	Height change to 2.4mm Max and added additional marking variation
23	11/07/19	Added G-sensitivity specification.
24	11/17/22	Model numbers updated

Bulletin	Tx176
Page	6 of 6
Revision	24
Date	17 Nov 2022