

COMET-REVA: Astera Labs USB-to-I2C Dongle

1 Introduction

Comet is Astera Labs’ USB-to-I2C Dongle, designed for communicating with the Astera Labs Retimer devices via I2C. By connecting the I2C interface of the dongle to the slave SMBus port of Astera Labs Retimer and using Astera Labs’ Python SDK, users can communicate with the Retimer device and retrieve diagnostics information. Contact info@Asteralabs.com for the SDK and SDK User’s Guide.

Key features:

- Support 1.8-V or 3.3-V I2C interface by selecting the voltage on J9
- Optional 2.2 kΩ pull-ups on the I2C SCL and SDA by installing or removing the jumpers on J14 and J15
- Support three I2C connections to the same I2C bus. The female connectors of the dongle can directly mate with the I2C male connector on the Astera Labs SVB.

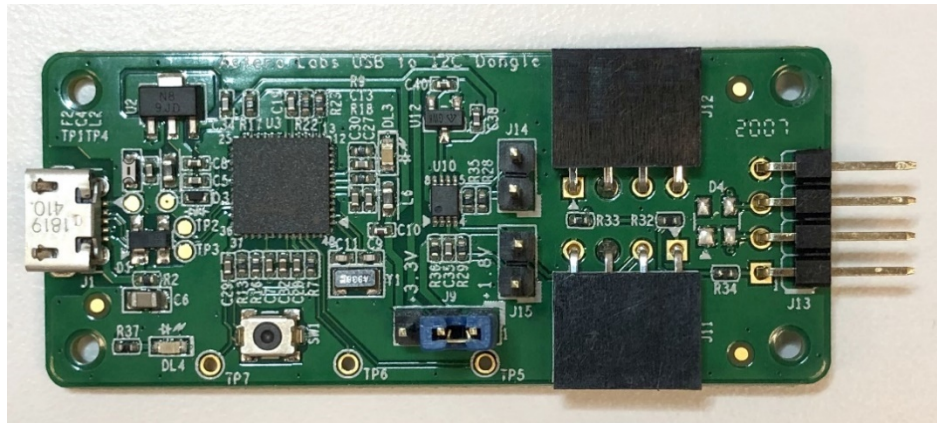
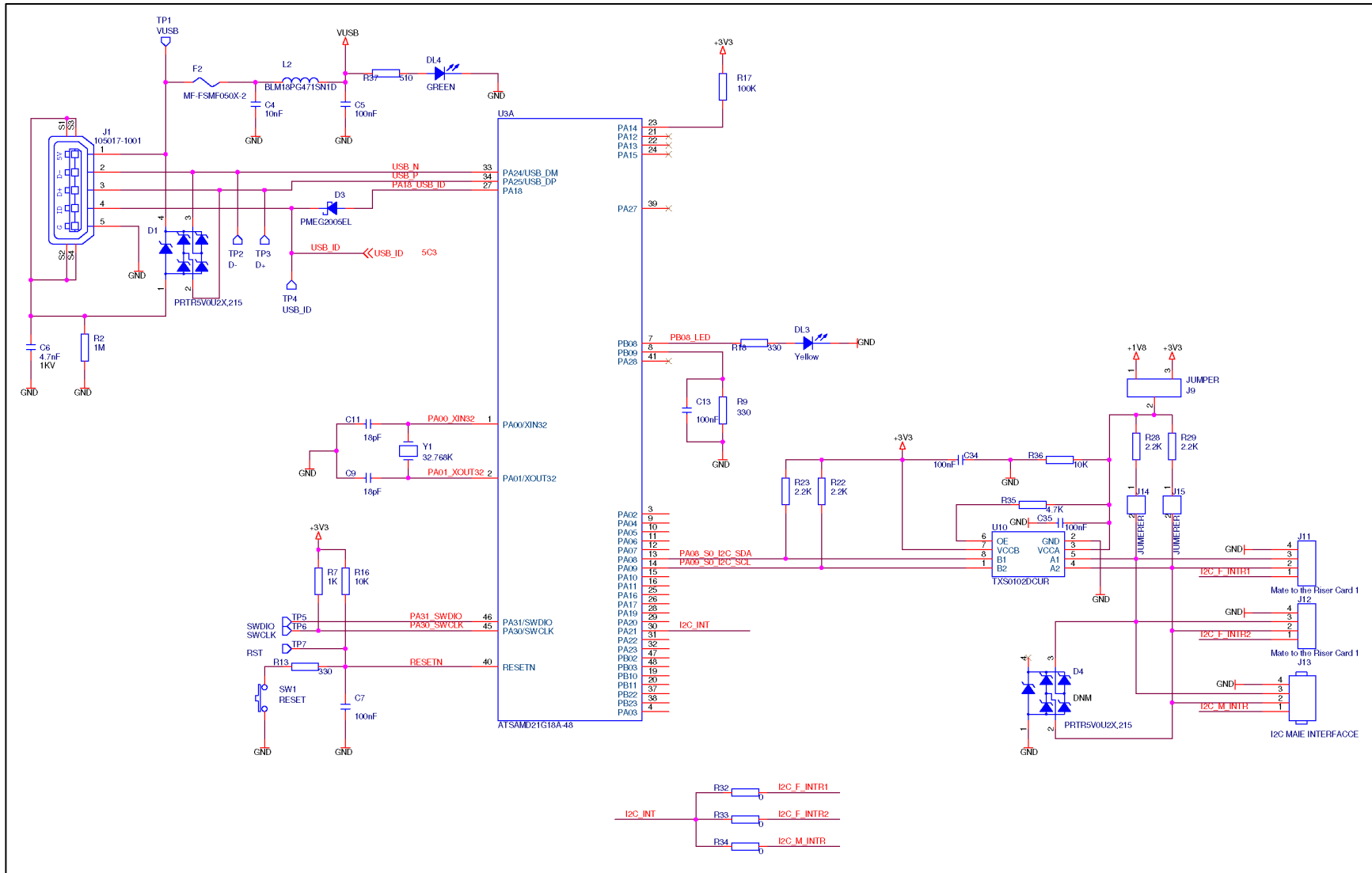

Figure 1: Top View



Figure 2: Bottom View

2 Schematics



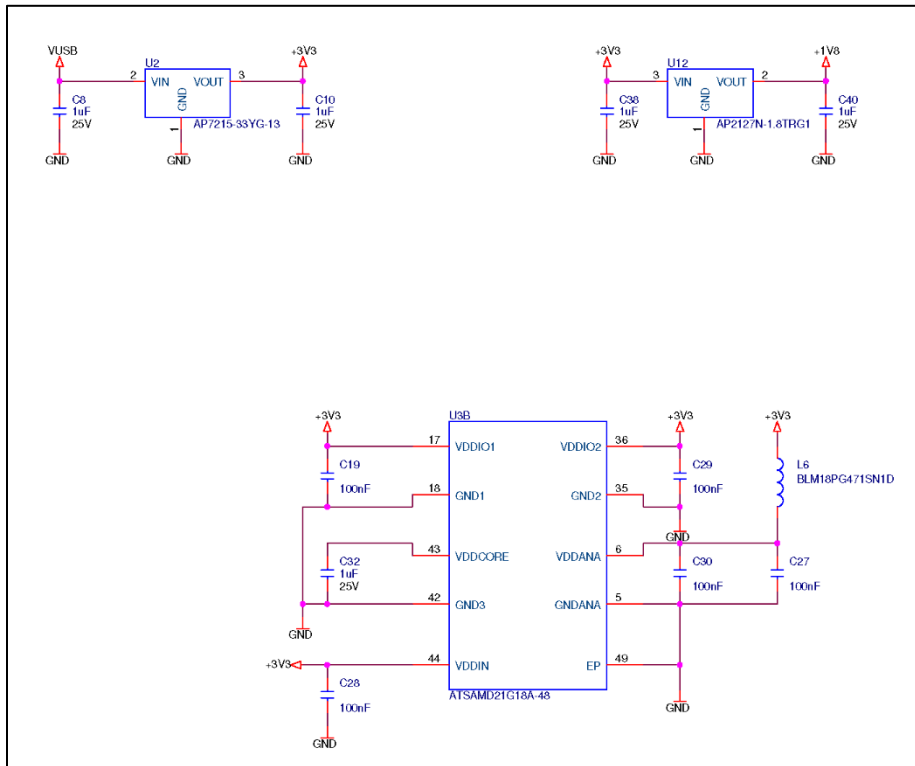

3 PCB Layout

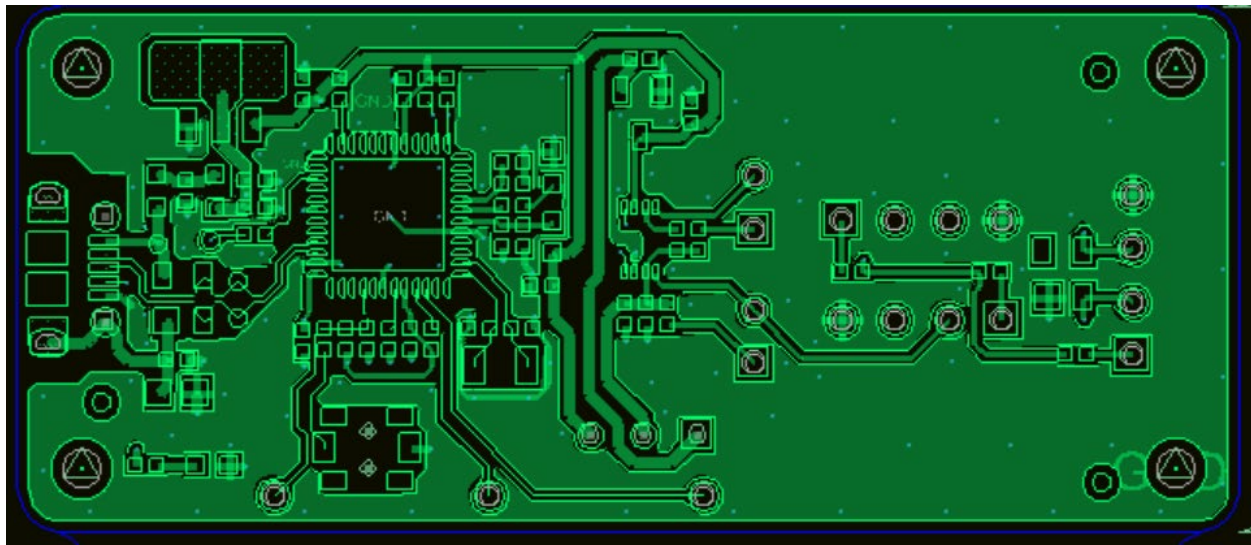

Figure 3: Top Side of PCB

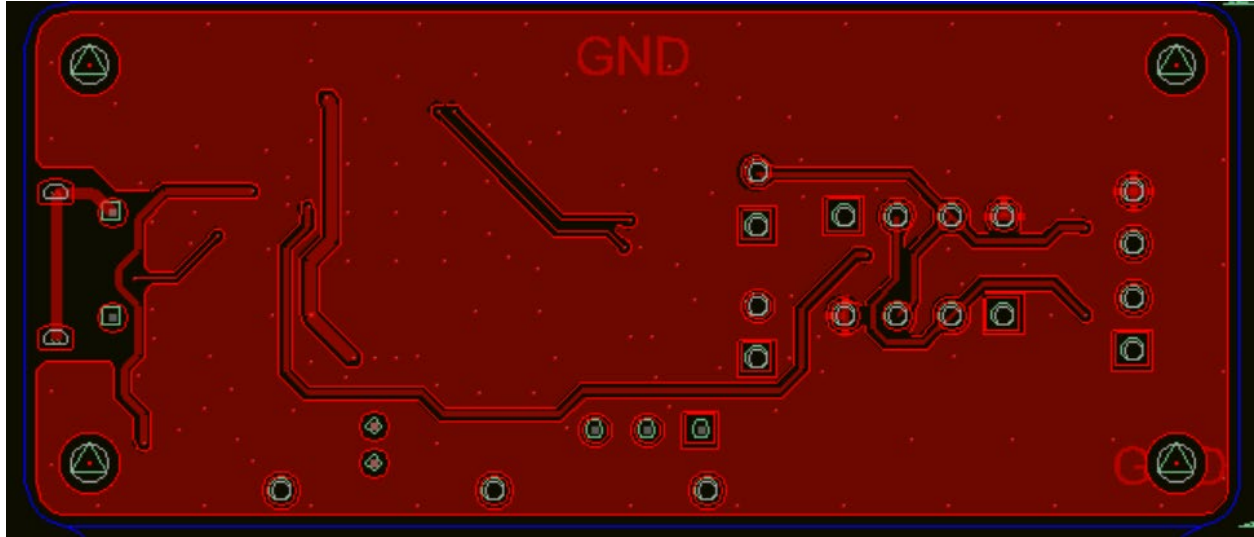

Figure 4: Bottom Side of PCB