

Rev.	DESCRIPTION	DATE	RESP	ECO

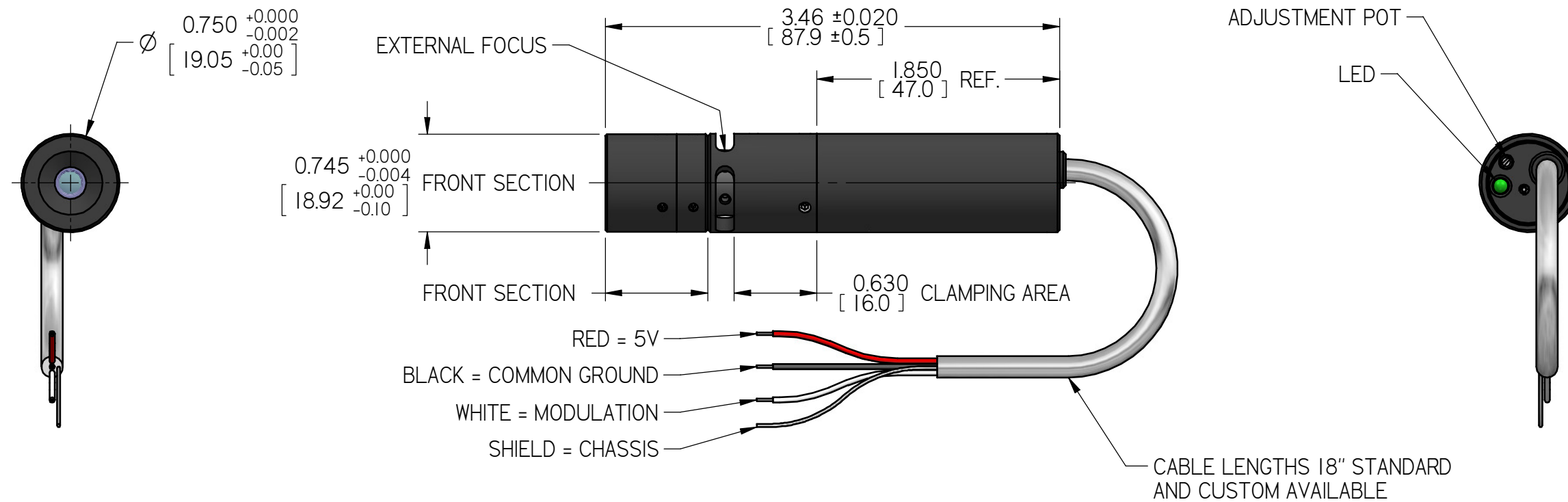

ISOMETRIC VIEW



NOTE : PART TO BE FREE OF BURRS AND SHARP CORNERS

This print or drawing shall be used only with reference to contracts or proposals of . Nothing disclosed herein not publicly available shall be used without written permission from COPYRIGHT ©	UNLESS OTHERWISE SPECIFIED : 1. DIMENSIONS ARE IN : INCH 2. TOLERANCES : FRACTIONS $\pm 1/64$ DECIMALS $XXX \pm 0.005$ $XX \pm 0.010$ $X \pm 0.015$ ANGLES $\pm 30'$ 3. SURFACE FINISH : $\sqrt{32}$	DESIGNER L.DIONNE		
		APPVL	SCALE : 1=1	
		FINISH N/A	SHEET: 1 DE 1	REF DWG
		TITLE STREAMLINE LASER ASSEMBLY REF. DRAWING		DATE 2011/05/19
				B
				DRAWING NO. 300-0052-REF
				REV.: 0